

Belt Driven Compressors



Compressor

Table of Contents

	Page
Introduction / Warranty	3
Standard Components	5
Compressor Layout	6
Installation	9
Engine Driven Compressors	11
Maintenance	13
Safety	14
Fault Analysis	15
Environment	16

Introduction / Warranty

FOR YOUR SAFETY AND THE SAFETY OF OTHERS ALWAYS READ FULLY THESE INSTRUCTIONS BEFORE OPERATING THIS COMPRESSOR

Introduction

Congratulations on the purchase of your SIP belt driven compressor. These compressors have been designed and manufactured to the highest standards and has been tested according to European Standards for a safe and trouble free operation.

Warranty

This Compressor is guaranteed against manufacturing defects for a period of 36 months from the date of purchase. Unless otherwise stated.

In order to give a satisfactory service the compressor **MUST** be correctly assembled, installed, maintained and used. The warranty against manufacturing defects depends on the user ensuring that the correct procedures are followed.

Always...

Ensure the correct power supplies are used. If the compressor is fitted with a 13A 3-pin plug, then it may be used on any domestic supply. See *Installation* on page 6

Inspect the compressor regularly and replace wearing parts and consumables as necessary. See *Maintenance* on page 11

This warranty does not cover items, which are considered to be consumable, i.e. Air intake filters, or items worn through general wear and tear. Nor defects caused by incorrect assembly, installation, maintenance or use.

ALL WARRANTY CLAIMS MUST BE ACCOMPANIED WITH RECEIPT OF PURCHASE

This manual and air receiver test certificate must be kept in a safe place and offered to everyone called to inspect, maintain or install your machine.

Important Notice!

All vessels manufactured
in accordance with Simple
Pressure Vessel Directive
87/404/EEC must be
fitted with Anti-Vibration
Mountings.

Failure to do so will
invalidate any guarantee.



Manufacturing Solutions

Divisions: • *Pressure Vessels* • *Machined Products* • *Metal Products* • *Special Products*



Standard Components

1. **Motor** Provides the power to turn the pump unit via the fly wheel.
2. **Pump Unit:** Compresses the air to the desired pressure.
3. **Receiver:** Air storage providing pulsation free air on demand.
4. **Pressure Switch:** Monitors the air pressure in the receiver and starts and stops the compressor automatically
5. **Receiver pressure gauge:** Indicates Air pressure in the receiver.
6. ***Outlet pressure gauge:** Indicates air pressure being used / delivered down the air line.
7. **Air Outlet Valve:** Gate valve to pressurize the airline. Some models have more than one outlet valve and can be regulated or unregulated.
8. ***Regulator:** Enables regulated air pressure to the outlet valve.
9. **Non-return valve:** Prevents the air pressure stored in the receiver to return back to the pump unit.
10. **Bleed pipe:** When the pressure switch turns off the motor any back pressure in the delivery pipe and pump unit is exhausted down this bleed pipe.
11. **Delivery pipe:** Delivers the compressed air from the pump to the receiver.
12. **Safety valve:** In the event of excessive pressure build up this valve will release the excess pressure to the atmosphere.
13. **Air intake filter:** Filters the intake of air to protect the pump unit from damage of air borne debris. On some models the filter is integral to the pumps head.
14. **Drain Valve:** Allows the draining of moisture build up inside the air receiver. This is a manual operation and must be done daily.
15. ***Wheels:** For portability.
16. ***Rubber feet:** To reduce vibration.
17. ***Oil Dip Stick:** To measure oil level also fill port for oil. Not on oil free models
18. ***After-cooler:** Passes compressed air in front of the flywheel to cool the air down.
19. ***Inter-cooler:** Passes the compressed between stages to cool the air down.
20. ***Motor Starter Box:** Used to start motor on larger models.

- Items marked with asterisks indicate that some compressors may not have this component.

Compressor Layout

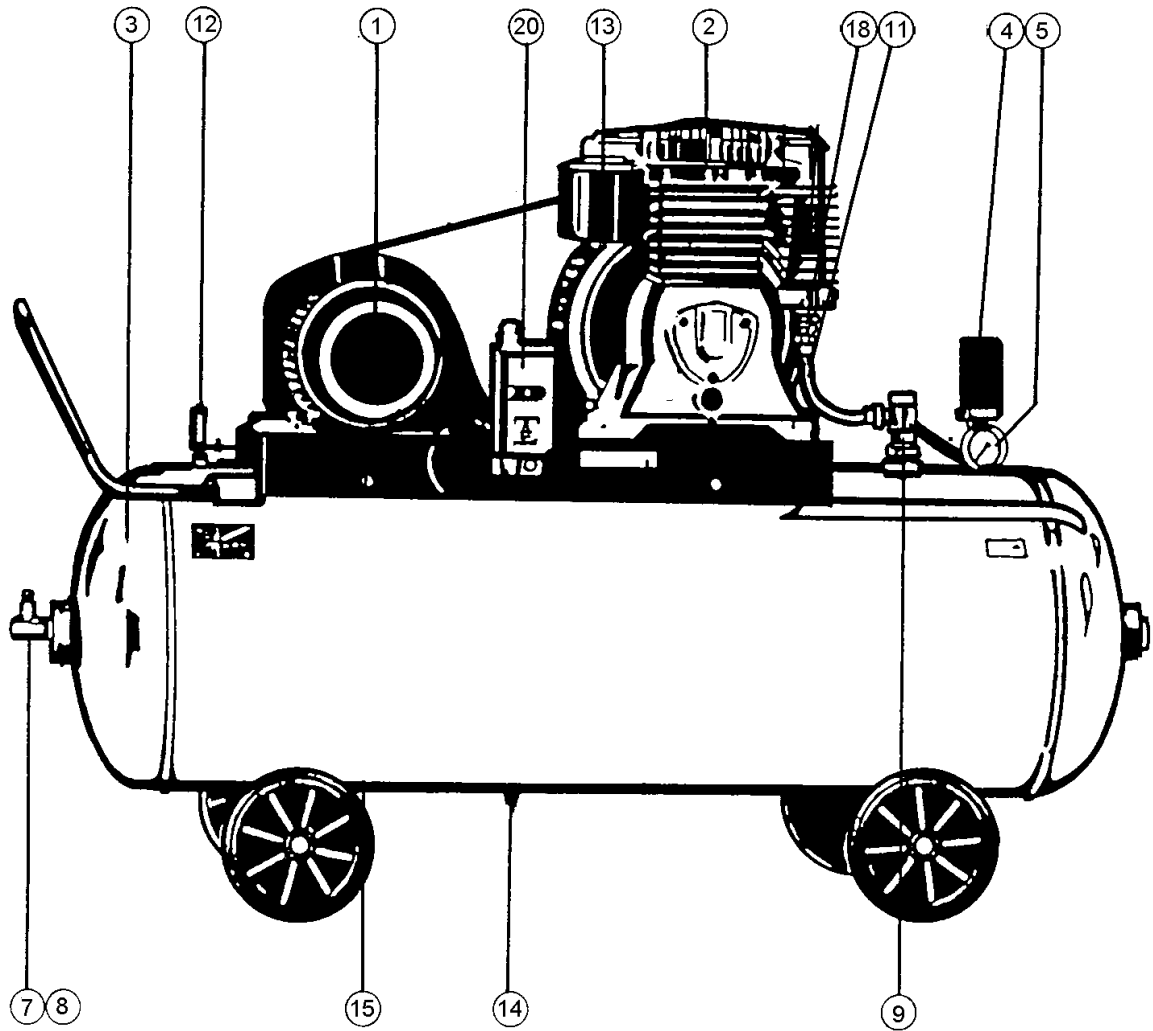

Installation

Your compressor arrives assembled and works tested, ready for installation and connection to your mains supply. On some models wheel mounting kits are supplied separately.

FOUNDATIONS: Belt Drive air compressors are supplied either static or wheel mounted. The static models require good ground conditions and **must be mounted to the correct type and size of anti vibration pads**. The wheel-mounted models absorb vibration but should be positioned on firm level ground.

SITING AND VENTILATION: Good access and headroom should be provided around the compressor for servicing. Adequate protection from the weather must also be provided. Good ventilation is vital, for maximum efficiency. Intake air should be as clean as possible. Air impurities, abrasive dust and corrosive gases are particularly harmful to the compressor.

MAINS CONNECTION: The compressor should be located as close to the mains supply as possible. Check that this supply is the same voltage as marked on the motor rating plate and that the wiring conforms in all respects to local regulations.

SINGLE PHASE MACHINES: 2HP 2.5HP & low current 3HP models will operate from a 30 amp ring main power supply with standard 13 amp outlets (standard domestic supplies). Standard 3HP & 3.5HP models will operate from a minimum of 15-amp power supply. Tandem single phase machines utilising two 3HP 1 phase motors, are supplied with an automatic control box. The control box must be wall mounted. It is designed to start the motors with a time delay in order to prevent double current surges on start-up. This unit should be connected to an adequate single-phase supply through a 32 amp fused isolator. It is recommended that motor start A2 size 32 M63 cartridge fuses are used. The supply cable to the automatic control box should be rated at 32 amps.

When any compressor is connected the flywheel must rotate **anti-clockwise** when viewed from the guard side of the compressor.

IMPORTANT:

The wires in the mains leads are colour coded in accordance with the following code:

SINGLE PHASE		THREE PHASE	
Brown or Red	Live	Black	Phase1
Blue or Black	Neutral	Blue	Phase2
Green/Yellow	Earth	Brown	Phase3
		Green/yellow	Earth

Three phase models are fitted with either 4 core cable (3 phases and earth) or 5 core cable (3 phases, neutral, and earth)

Connect to a suitable power supply according to local regulations. A competent electrician should only do electrical Installations.

This appliance must be earthed

Installation continued...

THREE PHASE MACHINES:

Units up to 7.5HP should be connected through a suitable fused isolator, using HRC fuse cartridges. Units 10HP and above are fitted with an automatic control box. The control box must be wall mounted. All units must be connected through a fused isolator, details of which are given below.

THREE PHASE MODEL	FUSED ISOLATOR	MOTOR RATED CARTRIDGE FUSE	OVERLOAD SETTING AMPS
2 HP	32 AMP	A2 13 AMP	4
3 HP	32 AMP	A2 16 AMP	5
3.5HP	32 AMP	A2 16 AMP	5.5
4 HP	32 AMP	A2 16 AMP	6
5.5 HP	32 AMP	A2 20 AMP	8
7.5 HP	32 AMP	A2 20 AMP	11
10 HP	32 AMP	A2 20 AMP	15
15 HP	32 AMP	A2 32 AMP	24
20 HP	63 AMP	A3 40 AMP	28

VOLTAGE DROP:

If the compressor is moved a long way from the mains supply, the motor may appear to be sluggish, slow, buzz or unable to start. This is due to VOLTAGE DROP caused by the extended lead to the compressor. This can be prevented, by increasing the size of the cable. Incorrect voltage at the motor will invalidate any guarantee.

STARTERS:

All machines are supplied either complete with starters which have a thermal overload protection device built into them or a thermal overload incorporated into the motor.

Should the protection device operate due to excessive current for any reason, the machine can be restarted after approximately 2 minutes time delay by pressing the reset button on the starter or the reset button on the motor terminal box - the unit must be switched off at the pressure switch before doing this

Installation continued...

BEFORE STARTING CHECK:

That the compressor is correctly installed and that the supply voltage is correct and all fuses are correctly rated and intact. Also, that all maintenance checks have been carried out and the contents of this manual have been read and fully understood, by all appropriate persons.

PRESSURE SWITCH STARTER BUTTON:

All machines are fitted with a black pressure switch combining a STOP/START button on the top. In the 'UP' position the motor will start, in the 'DOWN' position the motor will stop and the switch will bleed the pump head. If it is necessary to stop the machine before the normal cut - out pressure is reached this button should be depressed to stop it. NB: Some models may have a rotary switch instead of a push button.

STARTING: Before starting your compressor any compressed air left above the piston and in the delivery pipe should be exhausted to ensure the motor starts in a 'NO LOAD' condition. The air is exhausted by pressing down the button on the pressure switch and lifting it again to the 'ON' position. On completion of this procedure the motor will start up immediately.

AUTOMATIC RUNNING: Once started your compressor stops and starts automatically. This is controlled by the pressure switch which is preset at the factory to stop the motor when the pressure in the tank reaches it's maximum working pressure and to automatically restart the motor when the pressure in the tank decreases to a predetermined pressure (about 35psi below maximum working pressure). If for some reason you want to stop the compressor, and immediately start again, the compressed air above the piston must be bled, to unload the compressor on start up (see STARTING section above).

PRESSURE REGULATION: Your compressor may be fitted with a pressure regulator or combined air filter and pressure regulator. Simply turn the pressure control knob to adjust the outgoing pressure.

Engine Driven Compressors

FOR UNITS FITTED WITH AIR BLOW OFF VALVE

WARNING: WHEN IN USE THE ENGINE EXHAUST BECOMES VERY HOT - TAKE CARE

1. PRE-OPERATION CHECKS:

The following checks must be carried out BEFORE STARTING YOUR UNIT.

- a. Engine oil level - See engine owner's manual for oil type.
- b. Compressor oil level - use SIP Compressor Oil.

2. STARTING:

Follow the engine owner's manual.

- a. Set the fuel tap to the 'ON' position. (If fitted)
- b. Turn the ignition switch to the 'ON' position. (Not on diesel models)
- c. Move the choke lever to the closed position. (Not on diesel models)
- d. Move the throttle to the open position.
- e. Open the bleed valve located on the air blow off valve.
- f. Slowly pull the engine starting cord two or three times, then pull it quickly to start the engine. On diesel models the decompression device must be used. When the engine starts, IMMEDIATELY close the bleed valve on the air blow off valve.
- g. As the engine warms up gradually move the choke control to the 'OFF' position. (Not on diesel models)
- h. The machine will now run continuously as long as fuel is provided.

3. STOPPING:

Follow the engine owners manual.

To stop the engine the speed must be reduced by closing the throttle then switching off at the ignition switch (petrol models) or stop control (diesel models) If the machine is to be stored for any length of time the fuel must be drained from the fuel tank.

Engine Driven Compressors

4. AUTOMATIC AIR BLOW OFF/NON RETURN VALVE:

The machine is fitted with an automatic air blow off valve. When the pressure in the receiver reaches the preset maximum pressure the air blow off valve automatically transfers any further air to the atmosphere through a small silencer. The machine is left running in a virtually unloaded condition. When the receiver pressure reduces sufficiently the air blow off action is reversed and compressed air again enters the receiver. The machine can be left running continually if so desired.

WARNING: - DO NOT adjust the engine speed as it has been factory set to give optimum performance on the compressor. Any adjustment may result in damage to the engine or pump or excessive vibration. If the engine is stopped for any reason the pump pressure must be relieved before restarting. This is done, by loosening the bleed valve located on the air blow off valve, a 'hissing' sound will be heard. The engine can then be restarted in the normal manner, after starting retighten the bleed valve immediately, finger tight only.

WARNING:- THE BLEED VALVE BECOMES VERY HOT DURING NORMAL OPERATION

The air blow off valve is preset to a maximum pressure of 150 psi, this should not normally need adjusting. If re-adjustment is required to reset the maximum pressure to 150 psi loosen the locknut, turn the adjusting bolt, clockwise to increase pressure, anti-clockwise to reduce pressure, tighten the locknut. You must not adjust the air blow off valve to give a maximum receiver pressure in excess of 150 psi.

NOTE: The air blow off valve is designed so that if the engine is stopped with the pressure in the receiver at maximum (150 psi) it will automatically bleed down to approximately 110 psi.

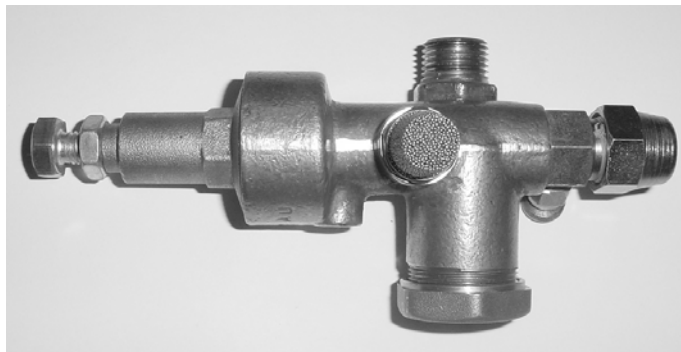

Maintenance

Engine: Read your engine manual thoroughly and carry out the checks, servicing and maintenance as described. Your local engine repair agent should be contacted in the event of any engine problem or failure, which needs expert attention.

Air Compressor: Read the rest of this manual thoroughly and implement the regular checks and duties indicated as appropriate.

Before carrying out maintenance.

Always make sure the compressor is turn off and isolated from the mains power supply and any stored compressed air is drained out of the receiver and airline system. Only a competent person should do internal inspections.

Cleanliness.

Always keep your compressor clean internally and externally. Change the oil regularly and keep all external surfaces clean. A clean inside leads to good mechanical efficiency, a clean outside means better dissipation of heat to the circulating air.

Pressure switch unloader valve.

On most pressure switches (usually black in colour) there is either a button or rotary switch which is used to turn the compressor on and off. This switch also activates the unloader valve to relief pressure in the delivery pipe and cylinder head to allow the motor to restart off load.. Depress this button or turn the rotary switch from time to time to ensure that the valve is working properly and exhausting the air.

Suction Action

Gently place your hand over the air inlet filter, the change in inlet suction noise should be heard. Poor suction would suggest a block air filter or damaged valves. Also causing excessive load onto the motor.

Piston Rings (not on fitted on all models)

Sealing rings and oil scrapper rings should be inspected annually or if excessive oil is being used by the compressor., worn rings should be replaced. An oil change should always accompany rings or other major component replacements. Followed be a further oil change 50 hours running or one week whichever is sooner.

Spare part lists and exploded drawings are available from your local distributors or by calling the SIP technical support desk.

All warranty claims must be accompanied by proof of purchase.

Scheduled Maintenance

Regular maintenance will ensure maximum efficiency for the longest period.

DAILY

Oil - check the crankcase oil level, and top up with oil if required. Use SIP compressor oil. Investigate high oil consumption; this indicates a possible pump problem.

If your compressor is not used daily, check crankcase oil level before starting up. The initial oil should be drained after 50 hours running or 1 week and thereafter every 500 hours or (4 months) whichever is sooner.

Water - should be drained from the air receiver by means of the drain valve located underneath the receiver. Simply unscrew the knurled ring to release the water, and re-tighten finger tight. A similar operation should be carried out on the after cooler and pressure regulator/filter (if fitted). Failure to drain the air receiver will invalidate the receiver warranty.

Leaks - check for leaks from the compressor, fittings, delivery lines and couplings re-tighten or re-seal as necessary. Remember, even small leaks can cause significant wastage of compressed air costing you both for extra energy used and reduced compressor life.

Cylinder head bolts - these should be checked and re-tightened with a torque wrench after the first days running, after 50 hours, and thereafter every 500 hours or four months, whichever is the sooner. The cylinder head needs to be completely cold before carrying out this operation.

Air Filter - check and clean by reverse blowing with compressed air, if badly contaminated, replace the cartridge.

WEEKLY OR AFTER 50 HOURS RUNNING (WHICHEVER SOONER)

Pressure Switch - observe that the compressor is cutting out at the correct maximum pressure, and back in approximately 35psi lower. If adjustment is necessary contact SIP for guidance.

Safety Valve - this is set to protect in case of pressure switch malfunction. With the receiver pressure at maximum, the centre shaft can be lifted with ease to check its function. Wear eye and ear protection during this check.

MONTHLY OR AFTER 200 HOURS RUNNING (WHICHEVER SOONER)

Belt Tension and Alignment - check with mains isolated - the motor pulley and pump flywheel should be in line and the movement on the Vee belt at it's midpoint should not exceed 12mm. At the same time check that motor securing bolts and pump securing bolts are tight, and check for belt wear. Also check that the pump flywheel and motor pulley are secure on their respective shafts and that the securing bolts are tight.

Safety

DO NOT:

1. Use compressed air for cleaning clothing.
2. Apply compressed air directly onto the skin
3. Use compressed air for breathing apparatus or charging breathing air cylinders, unless the air has been filtered using filters designed specifically for this purpose.
4. Use an open-air line, this will cause 'whip' and could cause injury.
5. Use flammable liquids to clean the compressor.
6. Use naked flames to inspect the interior of the compressor or pressure vessel.
7. Allow children or inexperienced people to operate or go near the compressor.
8. Touch the air compressor with wet hands.
9. Move the compressor when in operation.
10. Move the compressor in any other method than the way in which it has been designed.

DO:

1. Use eye protection when using compressed air to clean equipment.
2. Ensure dirt is not blown towards other people, always use a blow gun for cleaning.
3. Ensure all ancillary equipment is in good condition and correctly rated for the job.
4. Check regularly that covers and guards are secure and in position.
5. Fit a non-return valve or shut off valve in the delivery line if the compressor is to be coupled in parallel with another compressor or connected to an airline system.
6. Ensure that all pipe work and hoses connected to the compressor are the correct size and suitable for the working pressure. Also in good condition.
7. Switch of the compressor and isolate from the mains supply and discharge any stored air from the receiver or airline system, before carrying out maintenance.
8. Install the compressor so that an adequate supply of cooling air can circulate around the pump unit, and that air passage through the cover and motor fan inlets is not restricted.
9. Ensure all safety rules and regulations are complied with, in all aspects applicable to the working environment in which the compressor operates.
10. Always read the manual fully before operating this equipment.

Fault Analysis

FAULT SYMTOMS	Possible Cause
Pumping Oil	1, 7, 9, 11, 19, 20
Knocks and Rattles	2, 15, 16, 17, 18, 20, 24
Reduced air delivery	1, 5, 16, 19, 20, 24
Motor tripping out or drawing excess current	8, 13, 14, 16, 18, 20, 23, 27
Rusting Cylinders	11, 12
Excessive stopping and starting	3, 5, 6
Compressor running very hot	4, 6, 10, 16, 21
Compressor not coming up to speed	13, 27
Lights flicker when compressor runs	13, 14
Abnormal piston, ring or cylinder wear	7, 10, 11, 22
Motor will not run	13, 14, 25, 26, 27, 28

FAULT CHART

1. Clogged air intake filter.
2. Loose pulley, or excessive play in motor shaft.
3. Receiver needs draining.
4. Air to flywheel blocked or obstructed.
5. Air leaks in pipe work on or off compressor.
6. Receiver safety valve leaking.
7. Oil viscosity too low.
8. Oil Viscosity too high.
9. Oil Level too high.
10. Oil level too low.
11. Incorrect oil being used. Try SIP Compressor oil.
12. Extremely light duty use, or located in damp environment.
13. Check for good connections and voltages at motor terminals and starter box.
14. Poor power regulation.
15. Carbon on top of piston.
16. Leaking, broken, carbonised or loose valves or restricted airways.
17. Worn or scored connecting rod bearings.
18. Loose motor fan, defective bearings on crankshaft.
19. Broken piston rings.
20. Cylinders scratched or worn.
21. Incorrect direction of rotation. Anticlockwise when viewed from flywheel side.
22. Dusty atmosphere, dirty inlet filter.
23. Drive belt too tight.
24. Drive belt slack.
25. Faulty motor capacitors
26. Faulty pressure switch.
27. Faulty non-return valve.
28. Overload tripped.



QUALITY AND ENVIRONMENT DEPARTMENT

SIP (INDUSTRIAL PRODUCTS) LTD



**Congratulations upon your new SIP purchase.
We thank you for having purchased SIP equipment**

All SIP equipment has been designed, manufactured, tested and quality controlled to be complete and free of manufacturing defects in order to provide long trouble free service.

In the unlikely event that difficulties should be experienced with your new purchase, please refer to the enclosed instruction manual prior to contacting the SIP stockist from which the purchase was made. If the stockist is unable to rectify the problem encountered, they will contact us directly on your behalf.

In order to solve your problem quickly, you will need to provide the following information.

1. Type and model of product purchased.
2. Proof of purchase indicating date and supplier.
3. Use for which product is tasked.
4. Problem encountered.

With this data we will always endeavour to find a prompt resolution.

ENVIRONMENT

We believe that the protection of the environment is of paramount importance, not only on a day to day basis but also for our future generations. Please take the time to read this and make yourself aware of the environmental issues related to the product which you have purchased so that you may also contribute towards the protection of our future.

- 1) Please dispose of the packaging for the product in a responsible manner. It is suitable for recycling. Help to protect the environment, take the packaging to your local amenity tip and place it in the appropriate recycling bin.
- 2) If the product you have purchased requires oil changes to be carried out as part of the normal maintenance schedule please ensure that the waste oil is disposed of in a responsible manner. Under Section 111 of the Water Industry Act 1991 it is an offense to contaminate a drain or public sewer with oil. Most local amenity tips have oil disposal facilities. Please use them.
- 3) When the product you have purchased has reached the end of its useful service life or if you dispose of it for another reason, give consideration to the fact that the product does contain recyclable materials. Most local amenity tips have facilities to recycle these materials. Please use them.

Thank you for protecting the environment for yourself and future generations.

SIP (Industrial Products) Limited
Gelders Hall Road
Shepshed
Loughborough
Leicestershire
LE12 9NH
England