



Please dispose of packaging for the product in a responsible manner. It is suitable for recycling. Help to protect the environment, take the packaging to the local amenity tip and place into the appropriate recycling bin.



Never dispose of electrical equipment or batteries in with your domestic waste. If your supplier offers a disposal facility please use it or alternatively use a recognised re-cycling agent. This will allow the recycling of raw materials and help protect the environment.



01944

Bench Morticer with Sliding Table



FOR HELP OR ADVISE ON THIS PRODUCT PLEASE CONTACT YOUR DISTRIBUTOR.

Please read and fully understand the instructions in this manual before operation.

Keep this manual safe for future reference.

GENERAL SAFETY RULES

Woodworking can be dangerous if safe and proper operating procedures are not followed. As with all machinery, there are certain hazards involved with the operation of the product. Using the machine with respect and caution will considerably lessen the possibility of personal injury. However, if normal safety precautions are overlooked or ignored, personal injury to the operator may result. Safety equipment such as guards, push sticks, hold-downs, feather boards, goggles, dust masks and hearing protection can reduce your potential for injury. But even the best guard will not make up for poor judgment, carelessness or inattention. Always use common sense and exercise caution in the workshop. If a procedure feels dangerous, do not try it. Figure out an alternative procedure that feels safer. REMEMBER: Your personal safety is your responsibility.

This machine was designed for certain applications only. We strongly recommend that this machine cannot be modified and/or used for any application other than that for which it was designed. If you have any questions relative to a particular application, DO NOT use the machine until you have first contacted your local dealer to determine if it can or should be performed on the product.

WARNING: FAILURE TO FOLLOW THESE RULES MAY RESULT IN SERIOUS PERSONAL INJURY

1. **FOR YOUR OWN SAFETY, READ INSTRUCTION MANUAL BEFORE OPERATING THE TOOL.** Learn the tool's application and limitations as well as the specific hazards peculiar to it.
2. **KEEP GUARDS IN PLACE** and in working order.
3. **ALWAYS WEAR EYE PROTECTION.** Wear safety glasses. Everyday eyeglasses only have impact resistant lenses; they are not safety glasses. Also use face or dust mask if cutting operation is dusty.
4. **REMOVE ADJUSTING KEYS AND WRENCHES.** Form habit of checking to see that keys and adjusting wrenches are removed from tool before turning it "on".
5. **KEEP WORK AREA CLEAN.** Cluttered areas and benches invite accidents.
6. **DO NOT USE IN DANGEROUS ENVIRONMENT.** Do not use power tools in damp or wet locations, or expose them to rain. Keep work area well lighted.
7. **KEEP CHILDREN AND VISITORS AWAY.** All children and visitors should be kept a safe distance from work area.
8. **MAKE WORKSHOP CHILDPROOF** – with padlocks, master switches, or by removing starter keys.
9. **DO NOT FORCE TOOL.** It will do the job better and be safer at the rate for which it was designed.
10. **USE RIGHT TOOL.** Do not force tool or attachment to do a job for which it was not designed.
11. **WEAR PROPER APPAREL.** No loose clothing, gloves, neckties, rings, bracelets, or other jewelry to get caught in moving parts. Nonslip footwear is recommended. Wear protective hair covering to contain long hair.
12. **SECURE WORK.** Use clamps or a vise to hold work when practical. It is safer than using your hand and frees both hands to operate tool.
13. **DO NOT OVERREACH.** Keep proper footing and balance at all times.
14. **MAINTAIN TOOLS IN TOP CONDITION.** Keep tools sharp and clean for best and safest performance. Follow instructions for lubricating and changing accessories.

PART LIST For 01944

Part NO.	DESCRIPTION	Q'TY	Part NO.	DESCRIPTION	Q'TY
1	Handle	1	42	Table	1
2	Motor	1	43	Clamp Plate	1
3	Switch Box	1	44	Screw	2
4	Screw	1	45	Drift	1
5	Gear Shaft	1	46	shaft	2
6	Screw	1	47	Screw	1
7	Screw	1	48	Nut	2
8	Handle	3	49	Screw	1
9	Setting Collar	3	50	Screw	3
10	Guide Column	1	51	Rack	1
11	Screw	2	52	Sliding Plate	1
12	Localizer	1	53	Washer	3
13	Screw	2	54	Screw	3
14	Cover	2	55	Drift	4
15	Gear Casing	1	56	Screw	4
16	Handle	1	57	Gas Spring	1
17	Washer	4	58	Screw	1
18	Setting Collar	1	59	Washer	4
19	Bolt	4	60	Gear	1
20	Chisel Bushing	1	61	Bolt	4
21	Chisel	1	62	Screw	1
22	Screw	1	63	Drift	1
23	Nut	1	64	Screw	3
24	Drift	1	65	Washer	3
25	Base	1	66	Chuck	1
26	Screw	2	67	Switch	1
27	Knob	1	68	Column	1
28	Gear	1	69	Rack	1
29	Gear Shaft	1	70	Screw	6
30	Handle	1	71	Screw	2
31	Screw	1	72	Power Cord	1
32	Screw	2	73	Screw	4
33	Knob	1	74	angle block	1
34	Screw	1	75	(closing) ring	3
35	Lead Screw	1	76	Screw	1
36	Washer	2			
37	Connecting Bend	1			
38	Knob	1			
39	Lead Screw	1			
40	Pin	2			
41	Lead Nut	1			

Parts Diagram for 01944

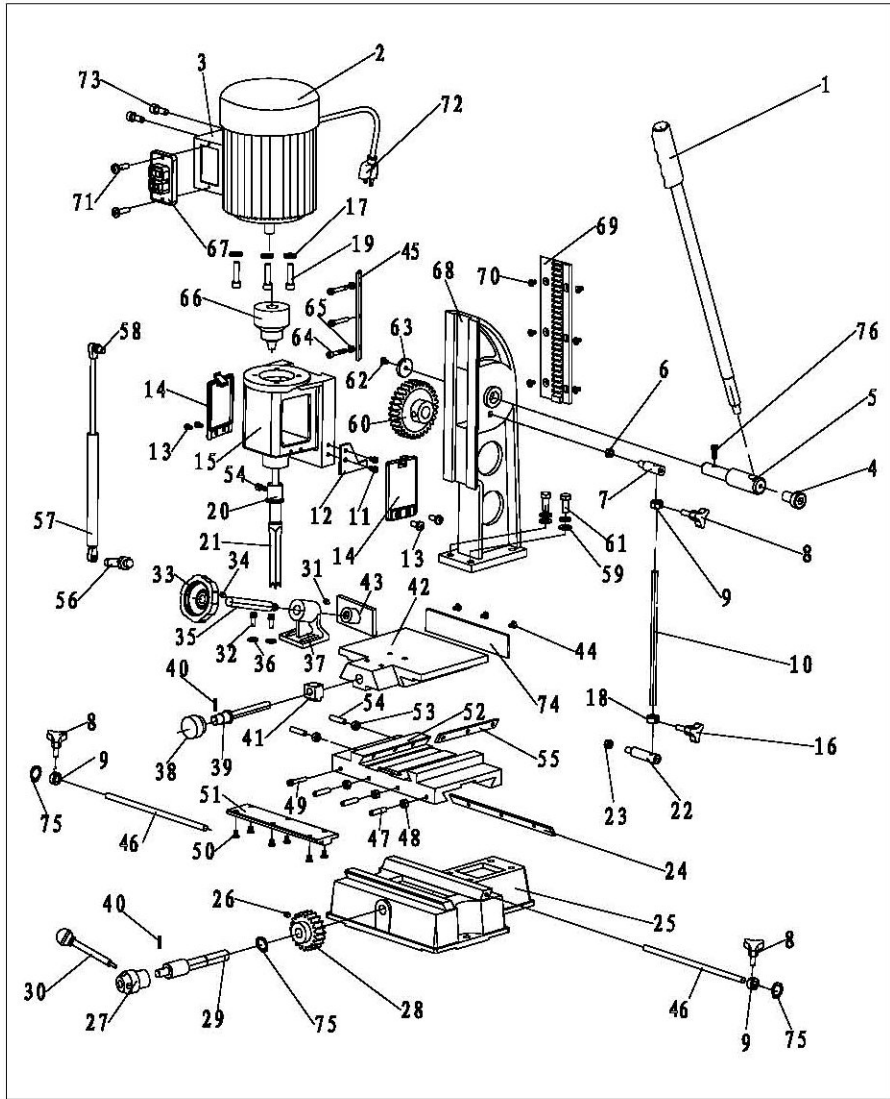

15. **DISCONNECT TOOLS** before servicing and when changing accessories such as blades, bits, cutters, etc.
16. **USE RECOMMENDED ACCESSORIES.** The use of accessories and attachments not recommended by manufacturer may cause hazards or risk of injury to persons.
17. **REDUCE THE RISK OF UNINTENTIONAL STARTING.** Make sure switch is in "OFF" position before plugging in power cord. In the event of a power failure, move switch to the "OFF" position.
18. **NEVER STAND ON TOOL.** Serious injury could occur if the tool is tipped or if the cutting tool is accidentally contacted.
19. **CHECK DAMAGED PARTS.** Before further use of the tool, a guard or other part that is damaged should be carefully checked to ensure that it will operate properly and perform its intended function – check for alignment of moving parts, binding of moving parts, breakage of parts, mounting, and any other conditions that may affect its operation. A guard or other part that is damaged should be properly repaired or replaced.
20. **DIRECTION OF FEED.** Feed work into a blade or cutter against the direction of rotation of the blade or cutter only.
21. **NEVER LEAVE TOOL RUNNING UNATTENDED. TURN POWER OFF.** Do not leave tool until it comes to a complete stop.
22. **STAY ALERT; WATCH WHAT YOU ARE DOING, AND USE COMMON SENSE WHEN OPERATING A POWER TOOL. DO NOT USE TOOL WHILE TIRED OR UNDER THE INFLUENCE OF DRUGS, ALCOHOL, OR MEDICATION.** A moment of inattention while operating power tools may result in serious personal injury.
23. **MAKE SURE TOOL IS DISCONNECTED FROM POWER SUPPLY** while motor is being mounted, connected or reconnected.
24. **THE DUST GENERATED** by certain woods and wood products can be injurious to your health. Always operate machinery in well-ventilated areas and provide for proper dust removal. Use wood dust collection systems whenever possible.
25. **WARNING: SOME DUST CREATED BY POWER SANDING, SAWING, GRINDING, DRILLING, AND OTHER CONSTRUCTION ACTIVITIES** contains chemicals known to cause cancer, birth defects or other reproductive harm. Some examples of these chemicals are:

- Lead from lead-based paints,
- Crystalline silica from bricks and cement and other masonry products, and
- Arsenic and chromium from chemically treated lumber.

Your risk from these exposures varies, depending on how often you do this type of work. To reduce your exposure to these chemicals: work in a well ventilated area, and work with approved safety equipment, such as those dust masks that are specially designed to filter out microscopic particles.

ADDITIONAL SAFETY RULES FOR HOLLOW CHISEL MORTISERS

1. DO NOT OPERATE THIS MACHINE until it is assembled and installed according to the instructions.
2. OBTAIN ADVICE FROM YOUR SUPERVISOR, instructor, or another qualified person if you are not familiar with the operation of this machine.
3. FOLLOW ALL WIRING CODES and recommended electrical connections.
4. MAKE CERTAIN the machine is fastened to a supporting surface to prevent it from tipping over during operation.
5. NEVER turn the morticer "ON" before clearing the table of all objects (tools, scrap pieces, etc.).
6. ALWAYS keep hands, fingers and hair away from the rotating bit.
7. DO NOT attempt to mortise material that does not have a flat surface, unless a suitable support is used.
8. ALWAYS position hold-down directly over work-piece to prevent work-piece from lifting during operation.
9. ALWAYS support work-piece securely against fence to prevent rotation.
10. BE SURE drill bit is sharp, not damaged, and properly secured in the chuck before operation.
11. MAKE SURE chuck key is removed before starting machine.
12. NEVER turn on the power with the drill bit or chisel contacting the work-piece.
13. NEVER perform layout, assembly, or set-up work on the table while the morticer is operating.
14. ADJUST the depth stop to avoid drilling into the table.
15. ALWAYS turn off the power before removing scrap pieces from the table.
16. SHUT-OFF the power, remove the drill bit and chisel, and clean the table before leaving the machine.
17. FOR YOUR OWN SAFETY - Don't wear gloves when operating the machine.
18. SHOULD any part of your tool be missing, damaged, or fall in any way, or any electrical component fail to perform properly, shut off switch and remove plug from power supply outlet. Replace missing, damaged, or failed parts before resuming operation.
19. THE USE of attachments and accessories not recommended by Delta may result in the risk of injuries.
20. TURN THE MACHINE "OFF" AND DISCONNECT THE MACHINE from the power source before installing or removing accessories, before adjusting or changing set-ups, or when making repairs.
21. TURN THE MACHINE "OFF", disconnect the machine from the power source, and clean the table/work area before leaving the machine. LOCK THE SWITCH IN THE "OFF" POSITION to prevent unauthorized use.

MAINTENANCE

The Morticer requires only minor maintenance, such as cleaning and lubrication and routine adjustment and sharpening of the chisel and bit.

Dust the machine down after each use and, as necessary, use light applications of oil or grease to lubricate linkages, moving parts, etc.

SHARPENING CHISEL & BIT

The chisel and bit should be kept sharp for best performance. Blunt edges will give inaccurate mortises and can lead to overheating and breakage to chisel or bit. If chisel and bit are badly worn and become difficult to sharpen, they should be replaced.

1. Sharpen the bit by using a small, smooth file, following the original shape of the bit. File the inside edge of the spur, the sides of the Brad point, and the cutting edge inwards toward the flute of the bit. See Fig. 8. Do not file the outside edge of the spur as this will affect the diameter of the bit.

2. Sharpen the chisel with a mortise chisel cutter with the correct size pilot. (Pilot size will differ depending on the size of your chisel). Two or three turns of the cutter in a carpenter's brace chuck should

be enough to sharpen the chisel, as shown in Fig. 9.

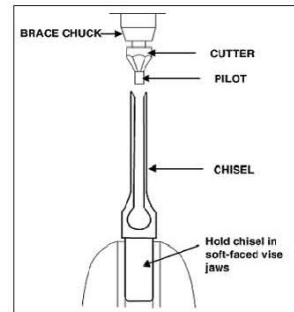

Fig 9

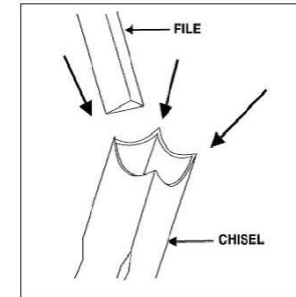

Fig 10

3. Use a small, triangular, smooth file to relieve the inner corners of the chisel. See Fig.10. Remove any burrs from the outside of the chisel with a fine oilstone.

FENCE

The fence (A) Fig. 5, can be moved in or out by loosening lever (B), sliding fence to the desired position and tightening lever (B).

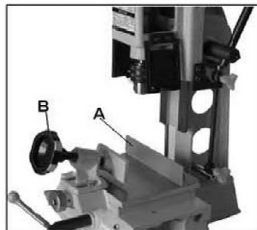

Fig5

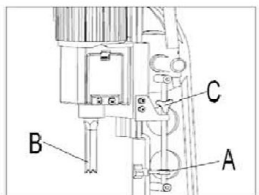

Fig6

DEPTH STOP

A depth stop guide (A) Fig. 6, is provided to limit the depth of the chisel (B). To adjust the depth stop guide (A), loosen handle (C) and lower head until the chisel (B) is at the desired depth. Lower depth stop guide (A) until it is at the desired depth, tighten handle (C).

INSTALLING CHISEL & BIT

1. Loosen lock screw, shown in Figure 7.

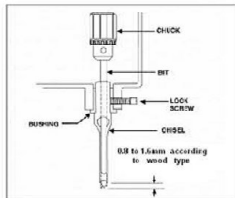

Fig 7

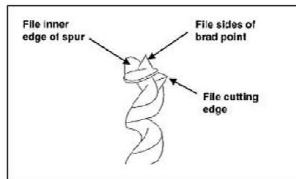

Fig 8

2. Insert chisel bushing (with the hole facing forward) into the head. Tighten the screw just enough to hold the chisel in place.

NOTE: Set the slot in the side of the chisel to the left or right, NOT to the front or back. This will allow chips to escape when cutting mortises.

3. Push the chisel up as far as possible into the head. Then lower the chisel approximately 0.8mm to 1.6mm, depending on the type of wood being worked. Tighten the screw to hold chisel in place.
4. Push bit up through the chisel opening as far as it will go. Lock the drill bit in place with the chuck key.
5. Loosen screw and push chisel up against the bushing, then tighten screw. This should provide the proper distance between the points of the chisel and the bit.

WARNING: FAILURE TO FOLLOW THESE RULES MAY RESULT IN SERIOUS PERSONAL INJURY.

SAVE THESE INSTRUCTIONS.

Refer to them often
and use them to instruct others.

CONNECTING TOOL TO POWER SOURCE

POWER CONNECTIONS

A separate electrical circuit should be used for your tools. If an extension cord is used, use only 3-wire extension cords, which have grounding type plugs and receptacles, which accept the tool's plug. Before connecting the motor to the power line, make sure the switch is in the "OFF" position and be sure that the electric current is of the same characteristics as indicated on the tool.

All line connections should make good contact. Running on low voltage will damage the motor.

WARNING: DO NOT EXPOSE THE TOOL TO RAIN OR OPERATE THE TOOL IN DAMP LOCATIONS.

MOTOR SPECIFICATIONS

Your tool is wired for 230 volt, 50Hz alternating current. Before connecting the tool to the power source, make sure the machine is cut off from power source.

GROUNDING INSTRUCTIONS

WARNING: THIS TOOL MUST BE GROUNDED WHILE IN USE TO PROTECT THE OPERATOR FROM ELECTRIC SHOCK.

All grounded, cord-connected tools:

In the event of a malfunction or breakdown, grounding provides a path of least resistance for electric current to reduce the risk of electric shock. This tool is equipped with an electric cord having an equipment-grounding conductor and a grounding plug. The plug must be plugged into a matching outlet that is properly installed and grounded in accordance with all local codes and ordinances.

Do not modify the plug provided - If it will not fit the outlet, have the proper outlet installed by a qualified electrician.

Improper connection of the equipment-grounding conductor can result in risk of electric shock. The conductor with insulation having an outer surface that is green with or without yellow stripes is the equipment-grounding conductor. If repair or replacement of the electric cord or plug is necessary, do not connect the equipment-grounding conductor to a live terminal.

Check with a qualified electrician or service personnel if the grounding instructions are not completely understood, or if in doubt as to whether the tool is properly grounded.

Use only 3-wire extension cords that have grounding type plugs and receptacles that accept the tool's plug.

Repair or replace damaged or worn cord immediately.

WARNING: IN ALL CASES, MAKE CERTAIN THE RECEPTACLE IN QUESTION IS PROPERLY GROUNDED. IF YOU ARE NOT SURE, HAVE A QUALIFIED ELECTRICIAN CHECK THE RECEPTACLE.

Use proper extension cords. Make sure your extension cord is in good condition and is a 3-wire extension cord, which has a grounding type plug and a receptacle, which will accept the tool's plug. When using an extension cord, be sure to use one heavy enough to carry the current of the tool. An undersized cord will cause a drop in line voltage, resulting in loss of power and overheating.

OPERATING INSTRUCTIONS

FOREWORD

Fox Model F14-652 is easier to operate than a conventional drill press equipped with a mortising attachment. The model F14-652 is made of cast-iron and steel for rigidity and stability. The mortiser comes with a standard 3-jaw type key chuck for positive gripping of mortising bits.

UNPACKING AND CLEANING

Carefully unpack the machine and all loose items from the shipping carton(s). Remove the protective coating from all unpainted surfaces. This coating may be removed with a soft cloth moistened with kerosene (do not use acetone, gasoline or lacquer thinner for this purpose). After cleaning, cover the unpainted surfaces with a good quality household floor paste wax.

NOTICE: THE MANUAL COVER PHOTO ILLUSTRATES THE CURRENT PRODUCTION MODEL. ALL OTHER ILLUSTRATIONS ARE REPRESENTATIVE ONLY AND MAY NOT DEPICT THE ACTUAL COLOR, LABELING OR ACCESSORIES AND MAY BE INTENDED TO ILLUSTRATE TECHNIQUE ONLY.

HOLLOW CHISEL MORTISER PARTS

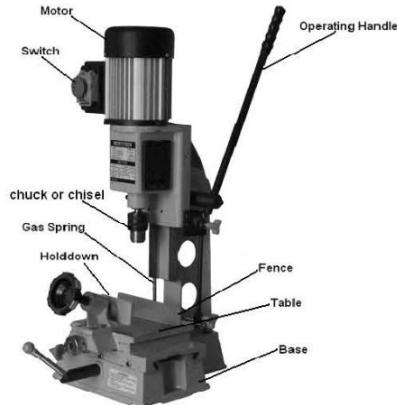

Fig. 1

ASSEMBLY

WARNING: FOR YOUR OWN SAFETY, DO NOT CONNECT THE MACHINE TO THE POWER SOURCE UNTIL THE MACHINE IS COMPLETELY ASSEMBLED AND YOU READ AND UNDERSTAND THE ENTIRE INSTRUCTION MANUAL.

RAISING AND LOWERING

HANDLE

1. Assemble hub of handle assembly (A) Fig. 2.

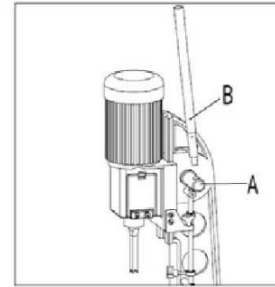

Fig 2

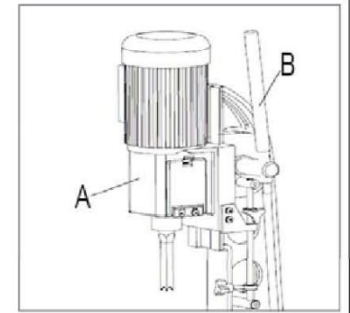

Fig 3

2. Raise mortising machine head (A) Fig. 3, to the up position by turning handle (B) clockwise.

OPERATING CONTROLS AND ADJUSTMENTS

RAISING AND LOWERING THE HEAD

The head (A) Fig. 4, is raised and lowered by means of the lever (B).

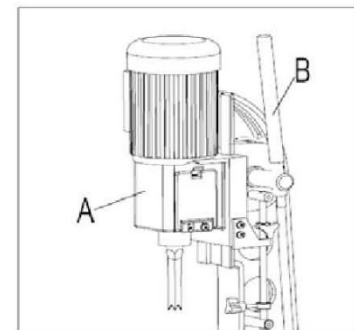

Fig 4